

Xm90 Magnetic Stripe Reader

POSX
www.pos-x.com



POINT OF SALE PERFECTED

The Xm90 magnetic stripe reader delivers consistent, reliable reads with every swipe. With a bi-directional swiping channel, LED indicator light and auditory beep, the Xm90 provides all the features found in a well-designed card reader. The included set up software is designed with an easy-to-use graphical interface, making complex programming effortless.

- ◆ Ideal for all point-of sale environments
- ◆ PS2 keyboard wedge, USB, or RS232 interface
- ◆ Single, dual, or three-track capacity

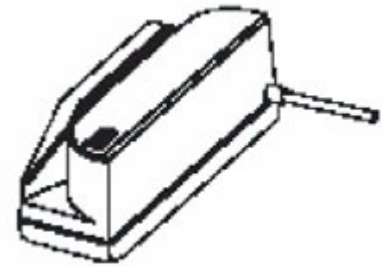
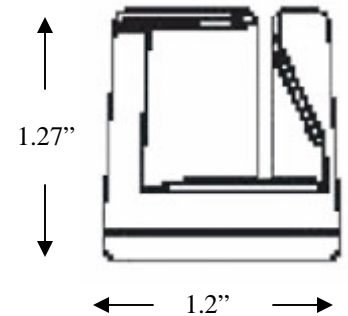
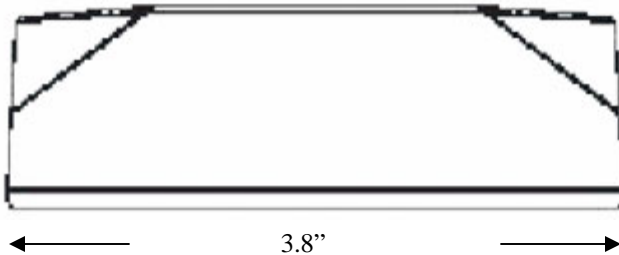

Models

Xm90U	Xm90 w/ USB Interface
Xm90K	Xm90 w/ KBW Interface
Xm90S	Xm90 w/ Serial Interface

SWIPE FUNCTION

Swipe Method	F2F Complied with ISO and JIS Standard
Swipe Speed	5 to 60 Inch/Sec.
Card Standard	Track #1 IATA Standard
	Track #2 ABA Standard
	Track #3 THRIFT Standard
	JIS-II, JIS x 6301 Standard
Card Density	Track #1 79 Characters (7 bit code)
	Track #2 40 Characters (5 bit code)
	Track #3 107 Characters (5 bit code)
	JIS-II 79 Characters (7 bit code)

WARRANTY

Parts	1 Year
-------	--------

PHYSICAL

Weight	.13lbs
Dimensions (LxWxH)	3.8" x 1.2" x 1.27"
Color	Black
Cable Length	4.9 Feet
Head Life	1,000,000 Passes Minimum
Power Supply	+5VDC± 10%
Current Consumption	<100mA
Interface	PS2 Keyboard Wedge, USB, RS232

ENVIRONMENTAL

Storage Temperature	-4° - 140° F
Operating Temperature	32° - 122° F
Operating humidity	20% - 90%